

- Small compact power packs used in lifting platforms, ramps and other applications
- 3 basic hydraulic circuits
- Low noise level
- High power ratio in relation to envelope dimensions
- Tank capacities from 7 to 30 L
- Possibility of building up an addition circuit in the form of horizontal stacking assembly of the size 04 or 06

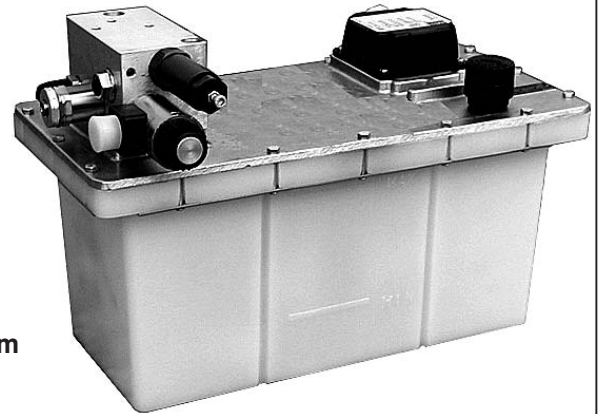

## Functional Description

The under oil power packs are designed for applications which require low noise level as well as small envelope dimensions. They are supposed to work only occasionally, thus being suitable mainly for the use in lifting platforms, elevating tables and handling devices. The electric motor (1) and the pump (2) are connected through a cross coupling. The electric connection of the electric motor with the power pack terminal board is realized through a tight bushing (4) which is fixed to the tank cover. The whole drive (electric motor + pump) is flexibly suspended by means of holder on the lower side of the tank cover.

Mounted on a lug, which is situated on the upper side of the tank cover, is block (5). The fluid under pressure delivered by the pump is led to this block by hose (6). The filtration of the fluid is provided by suction filter (7). The air is filtered by an air filter which is integrated into the filling plug (10). The filling plug serves also as the scale for measuring the oil level. The block according to the hydraulic circuit S11 forms the base, on which the connecting plates of the horizontal stacking assembly (size 04 or 06) can be mounted.

### PHASE - CONNECTIONS FOR CORRECT DIRECTION OF MOTOR ROTATION

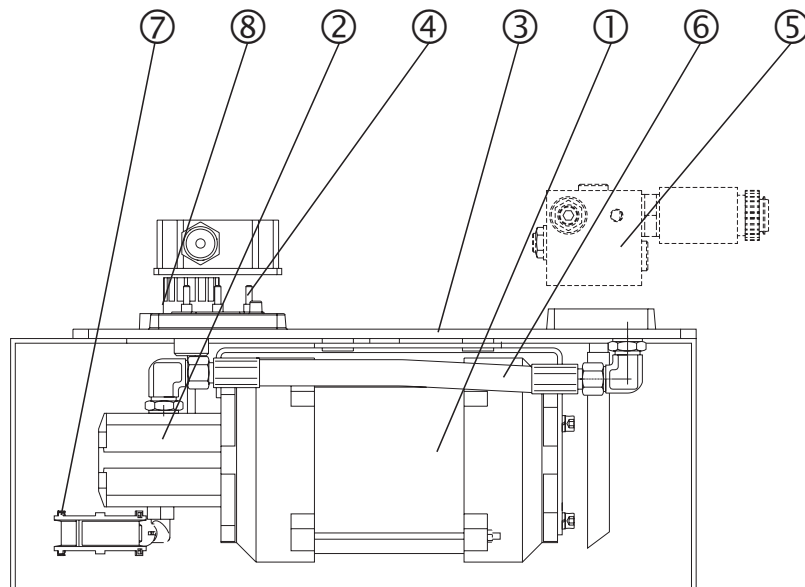
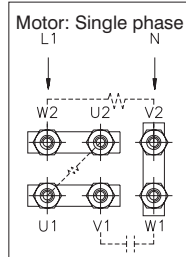
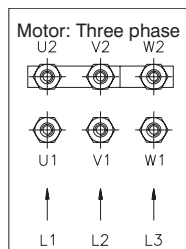

## Ordering Code

SPA 01 -  /  -  -  - **XXXX** /

Under oil power pack

Displacement of the pump  
in cm<sup>3</sup>

0,8	<b>08</b>
1,2	<b>12</b>
1,6	<b>16</b>
2,1	<b>21</b>
2,5	<b>25</b>
3,3	<b>33</b>
3,6	<b>36</b>
4,4	<b>44</b>
4,8	<b>48</b>
5,8 cm <sup>3</sup> /Um.	<b>58</b>
6,2 cm <sup>3</sup> /Um.	<b>62</b>
7,9 cm <sup>3</sup> /Um.	<b>79</b>

Code of the electric motor - see Tab. 1

Type of the block - see page 3

Solenoid voltage

<b>01200</b>	12V DC
<b>01400</b>	14V DC
<b>02100</b>	21V DC
<b>02400</b>	24V DC
<b>04200</b>	42V DC
<b>04800</b>	48V DC
<b>06000</b>	60V DC
<b>10200</b>	102V DC
<b>20500</b>	205V DC
<b>02450</b>	24V / 50 (60)Hz
<b>11550</b>	115V / 50 (60)Hz
<b>23050</b>	230V / 50 (60)Hz

Type No. - determined by manufactured

Code of the tank

<b>7</b>	7 L
<b>10</b>	10 L
<b>20</b>	20 L
<b>30</b>	30 L

## Technical Data

Flow rate	L/min	Tab. 1	
Working pressure	bar	Tab. 1	
Max. working/peak pressure	bar	Tab. 1	
Tank capacity	L	7,10, 20, 30	
Type of the pump		external gear pump	
Power of the electric motor	kW	0,55 to 3	
Load factor of the electric motor	%	20	
Type of the electric motor		single phase	three phase
Voltage of the electric motor	V	230	400
Frequency	Hz	50	50
Enclosure type of the electric motor		IP 54	
Hydraulic fluid		Hydraulic oils of power classes HM, HV to CETOP RP 91 H in viscosity classes ISO VG 32, 46 and 68	
Viscosity range	mm <sup>2</sup> /s	20 ... 100	
Maximum degree of fluid contamination		Class 21/18/15 to ISO 4406 (1999).	
Fluid temperature range	°C	-30 ... +80	
Ambient temperature max.	°C	up to 50	
Thread of the connecting ports P, T, M, (A, B)		G 1/4	
Working position		horizontal	

Tab. 1

Code of the electric motor			Code of the pump					
			08 P2..	12 P2..	16 P2..	21 P2..	25 P2..	33 P2..
p <sub>max.</sub> ** [bar]			250					
R.P.M.	400 V	kW	Q / p <sub>n</sub> * [l/min] / [bar]					
1500	13	0.55		1.5/175	2.0/130	2.6/100	3.1/85	4.2/65
	14	0.75			1.9/190	2.5/145	3.0/120	3.9/90
	15	1.1			2.1/200	2.8/190	3.3/160	4.4/120
	16	1.5					3.2/200	4.2/170
	17	2.2						
	18	3.0						
3000	30	0.55	2.2/120	3.2/80	4.3/60	5.6/45	6.7/40	8.9/30
	31	0.75	2.2/160	3.2/110	4.3/80	5.6/65	6.7/55	8.9/40
	32	1.10	2.2/200	3.2/165	4.3/120	5.6/95	6.7/80	8.9/60
	33	1.50		3.2/200	4.3/165	5.6/130	6.7/110	8.9/80
	34	2.20			4.2/200	5.5/190	6.6/160	8.7/120
	35	3.00					6.4/200	8.5/170
Um./min	230 V	kW	Q / p <sub>n</sub> * [l/min] / [bar]					
1500	5	0.55		1.6/165	2.1/125	2.7/100	3.2/80	4.3/60
	6	0.75		1.6/200	2.1/170	2.8/130	3.3/110	4.4/80
	7	1.10				2.8/190	3.3/160	4.4/120
	8	1.50					3.3/200	4.4/165
Code of the electric motor			36 P2..	44 P2..	48 P2..	58 P2..	62 P2..	79 P2..
p <sub>max.</sub> ** [bar]			250			200		
R.P.M.	400 V	kW	Q / p <sub>n</sub> * [l/min] / [bar]					
1500	13	0.55	4.5/60	5.5/50	6.0/45	7.3/35	7.8/35	9.9/25
	14	0.75	4.3/85	5.2/70	5.7/65	6.9/50	7.4/50	9.4/40
	15	1.10	4.8/110	5.8/90	6.3/85	7.7/70	8.2/65	10.4/50
	16	1.50	4.6/155	5.6/130	6.2/115	7.4/100	8.0/90	10.1/70
	17	2.20		5.0/200	5.5/190	6.6/160	7.1/150	9.0/120
	18	3.30			5.9/200	7.1/200	7.6/190	9.7/150
3000	30	0.55						
	31	0.75	9.7/35					
	32	1.10	9.7/55	11.8/45	12.9/40	15.6/35		
	33	1.50	9.7/75	11.8/60	12.9/55	15.6/45	16.7/40	
	34	2.20	9.5/110	11.6/90	12.7/85	15.3/70	16.4/65	20.9/50
	35	3.00	9.3/155	11.3/125	12.4/115	15.0/95	16.0/90	20.4/70
R.P.M.	230 V	kW	Q / p <sub>n</sub> * [l/min] / [bar]					
1500	5	0.55	4.7/55	5.7/45	6.2/40	7.5/35	8.0/30	10.2/25
	6	0.75	4.8/75	5.9/60	6.4/55	7.7/45	8.3/45	10.5/35
	7	1.10	4.8/110	5.9/90	6.4/80	7.7/70	8.5/65	10.5/50
	8	1.50	4.8/150	5.9/120	6.4/110	7.7/95	8.5/85	10.5/70

\* p<sub>n</sub> - nominal pressure = the highest working pressure allowed without time restriction

\*\* p<sub>max.</sub> - maximum pressure = maximum pressure allowed for a short time - max. 20s

## Type of the hydraulic circuit

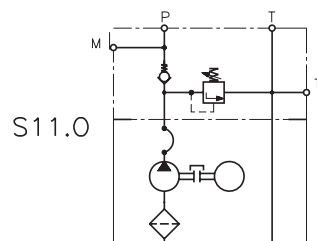

S11.0

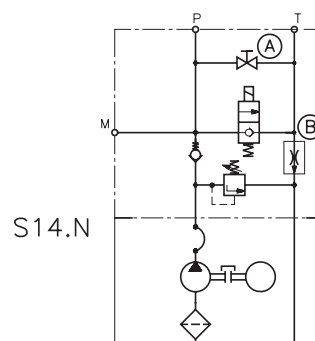

S14.N

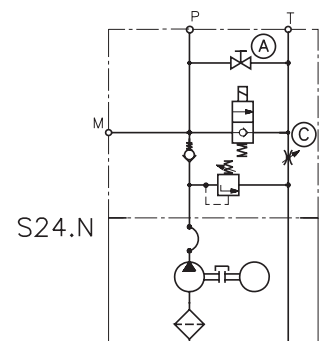

S24.N

**The hydraulic circuit S11.0** enables the power pack to be used as a simple pressure supply for general applications with the possibility to build up additional hydraulic circuits in the form of horizontal stacking assemblies of the size 04 or 06. Should the power pack be run for longer time periods, it is necessary to take the load factor of the electric motor into account.

**The hydraulic circuit S14.N and S24.N** enable the power pack to be used as pressure supply for lifting platforms and other devices, in which the mass of the system provides returning into the basic position. The shuf-off valve (A) enables emergency lowering of the device, should a disconnection of the supply voltage occur.

**The hydraulic circuit S14.N** comprises a flow control valve VSK2 (B) which is adjustable only in a certain range (see catalogue VSK2 - HA 5121). The valve is accessible after removing the block from the tank cover. If not otherwise required, a valve VSK2 is mounted into the block. The stabilized flow rate of this valve corresponds with the respective flow rate of the power pack (see Tab. 1).

**The hydraulic circuit S24.N** comprises a throttle valve VSV1-06 (C) without pressure compensation. This valve is accessible from outside of the block.

# Valve Dimensions

Dimensions in millimeters

## Steel tank

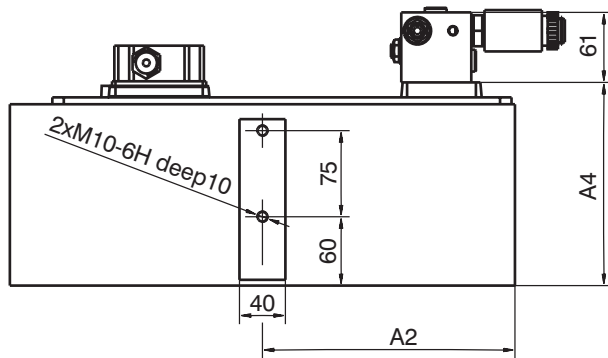

## Example of horizontal stacking assembly

- possible only with hydraulic circuit S11.0

E - according to the elements used, see datasheet 5021, 5023, 5051, 5091

F - Size 04=40 mm

Size 06=50 mm

G - Size 04=79 mm

Size 06=92 mm

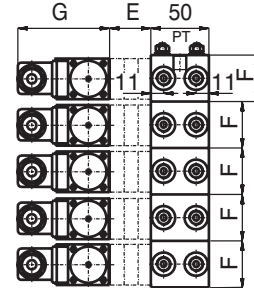

Throttle valve VSV1-06 (C)

Block S24.N

Block S14.N

Block S11

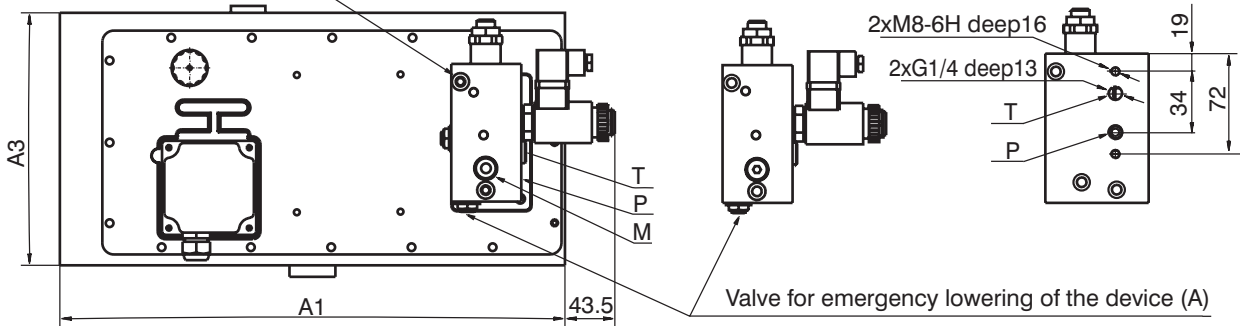

## Plastic tank

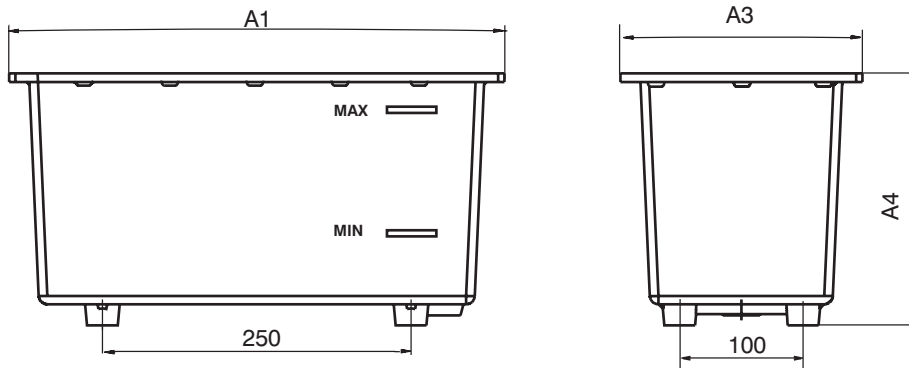

Code of the tank	Tank capacity in L	A1 mm	A2 mm	A3 mm	A4 mm
10 (sheet)	10	440	220	200	174
20 (sheet)	20	500	220	260	214
30 (sheet)	30	500	220	260	294
7 (plastic)	7	401	-	196	223

## Caution!

- The packing foil is recyclable.
- The technical information regarding the product presented in this catalogue is for descriptive purposes only. It should not be construed in any case as a guaranteed representation of the product properties in the sense of the law.

ARGO-HYTOS a. s. CZ - 543 15 Vrchlabí  
 Tel.: +420-499-403111, Fax: +420-499-403421  
 E-mail: sales.cz@argo-hytos.com  
 www.argo-hytos.com