

Gas Bottles

An Overview

Why Use Gas Bottles?

A standard hydro-pneumatic accumulator can provide approximately 25 to 30% of its fluid capacity in usable volume (e.g., approx. 38 gallons of capacity in a piston-type to obtain 10 gallons of fluid volume; approx. 42 gallons of capacity in a bladder-type to obtain 10 gallons of fluid volume).

The size of the accumulator can be reduced, though, by providing additional gas volume to the accumulator in order to expel a greater percentage of usable fluid volume from the unit (e.g., with Piston-type, the addition of approx. 28 gallons of pressurized gas capacity will allow the reduction of the necessary accumulator volume to

14 gallons and still receive 10 gallons of usable fluid volume; with Bladder-type, the addition of approx. 31 gallons of pressurized gas capacity will allow the reduction of the necessary accumulator volume to 11 gallons and still receive 10 gallons of usable fluid volume) Note: above approximations based on 3000 PSI max pressure/2000 PSI min pressure.

Since gas bottles are simply pressure vessels utilized to store a quantity of pressurized gas (normally nitrogen) without an internal bladder or piston, the effective cost per gallon of volume is less than the accumulator itself, thereby making gas bottles a cost-effective method of supplementing fluid volumes.

Example of Typical Gas Bottle/Accumulator System

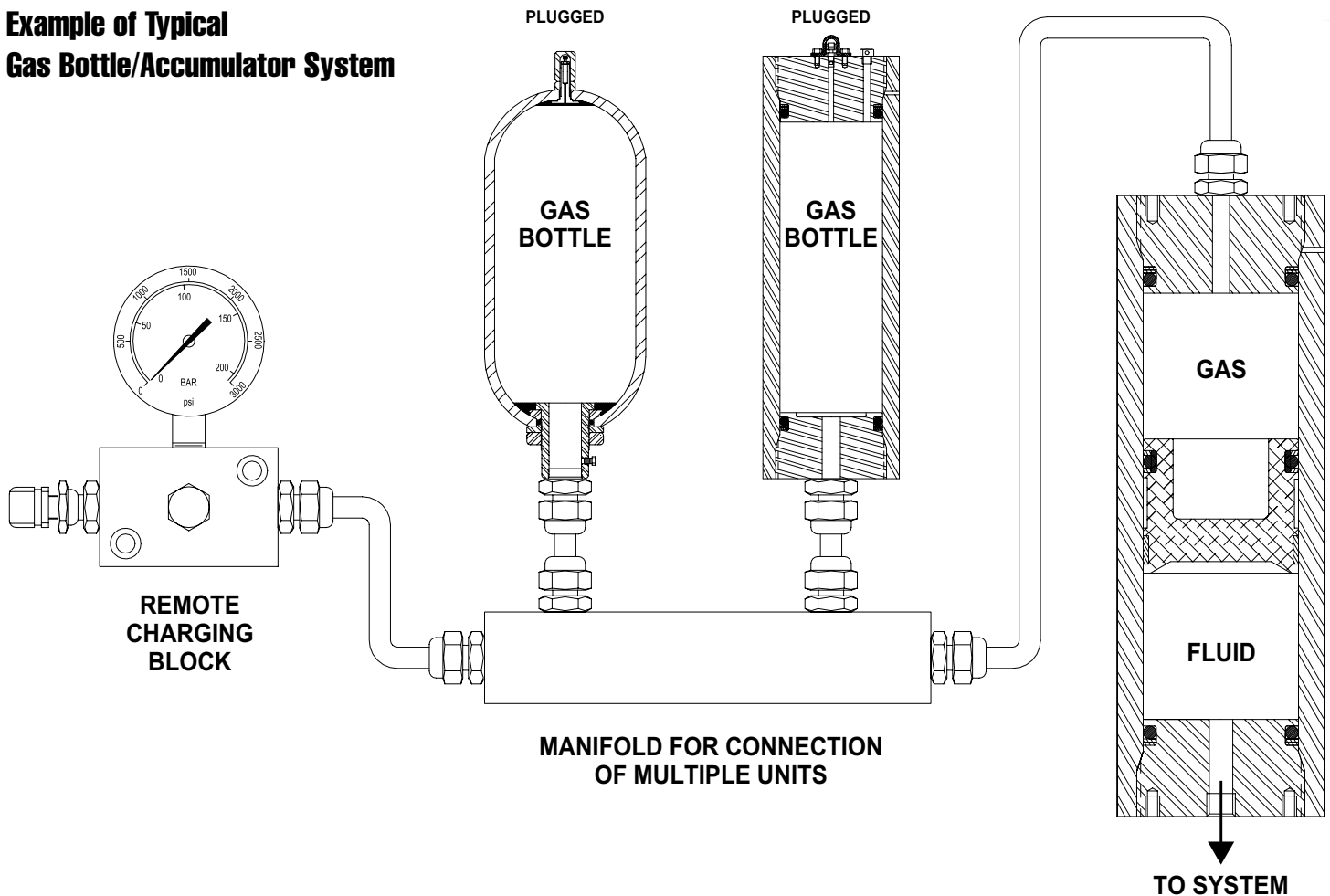

Gas Bottles

Forged Carbon Steel Shell

Forged steel shells without internal gas bladders are a cost-effective approach to providing additional gas volumes to selected systems.

Generally, these pressure vessels with hemispherical ends are readily available in the marketplace, and can sometime lead to a lower initial cost. Available only in a limited selection of sizes, though, multiple units may be “banked” (e.g., installed on a common manifold or header) to provide the required cumulative volumes.

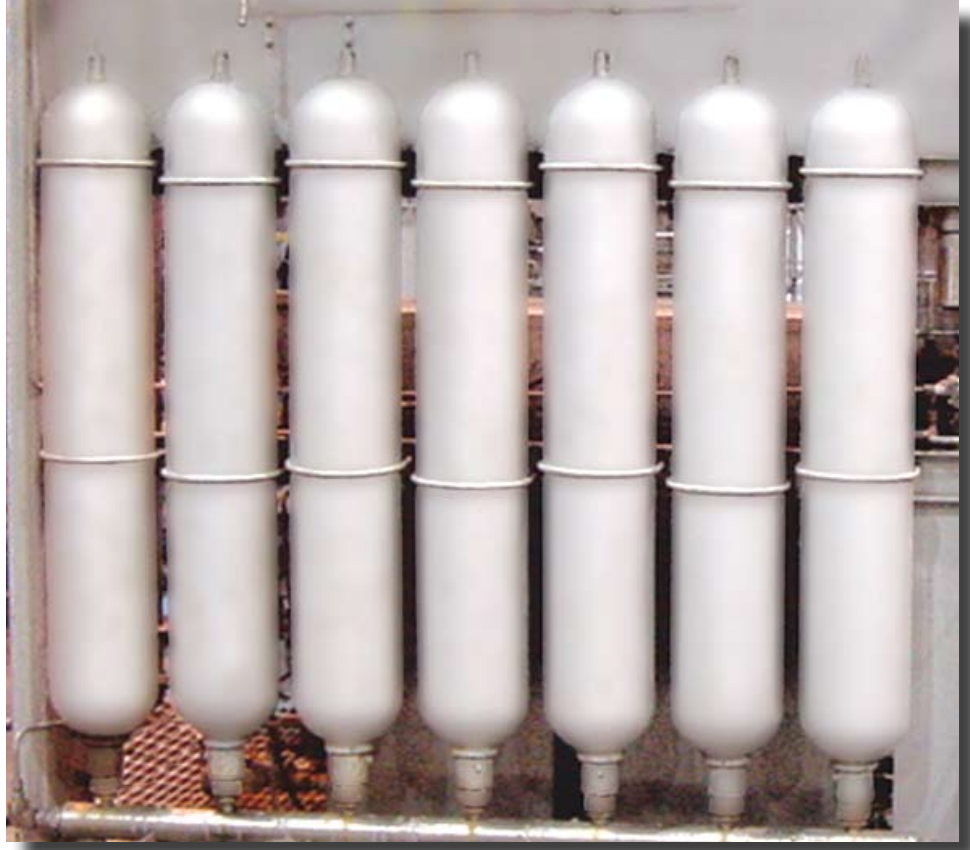

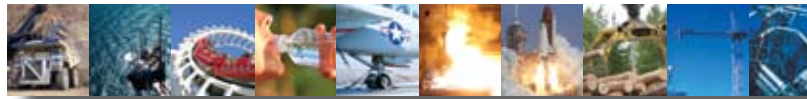

TBRG30

Gas Bottles 3,000 PSI (207 Bar)

MODEL NUMBER	GAS CAPACITY		FLUID CAPACITY		DRY WEIGHT		DIMENSION			
	In. ³	Cm. ³	Gallon	Liters	Lbs.	Kg.	A		B	
							In.	mm.		
TBRG30-2.5	577.5	9463	2.5	10	80	36	21	533	SAE-24 or 2" NPT available as standard. To specify 2" NPT, add "P" to end of Accumulator Model Number.	
TBRG30-5	1,155	18,927	5	19	126	57	33.25	845		
TBRG30-10	2,310	37,854	10	38	205	93	54	1,372		
TBRG30-11	2,541	41,639	11	42	226	103	59.5	1,511		
TBRG30-15	3,465	56,781	15	57	297	135	77.5	1,969		

GENERAL DESIGN DATA

Maximum Working Pressure 3,000 PSI (207 Bar)

Maximum Proof Pressure 4,500PSI (310Bar)

Operating Temperature

(Buna/Nitrile) -20° to +200°F (-28° to 93°C)

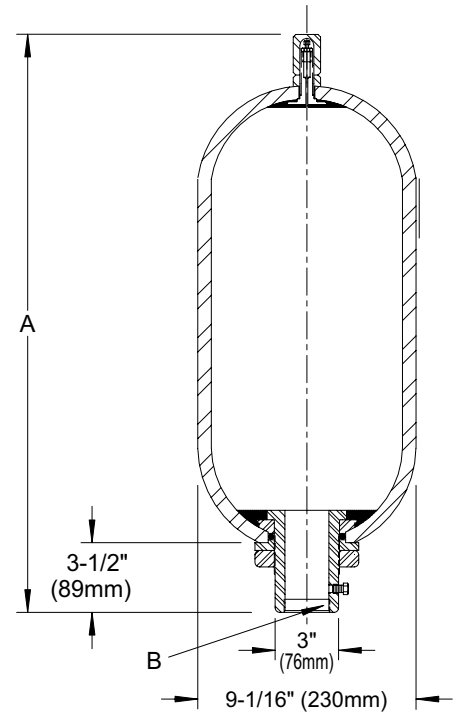

TBRG50

Gas Bottles 5,000 PSI (345 Bar)

MODEL NUMBER	GAS CAPACITY		FLUID CAPACITY		DRY WEIGHT		DIMENSION			
	In. ³	Cm. ³	Gallon	Liters	Lbs.	Kg.	A		B	
							In.	mm.		
TBRG50-2.5	577.5	9463	2.5	10	130	59	21.5	546	SAE-24 or 2" NPT available as standard. To specify 2" NPT, add "P" to end of Accumulator Model Number.	
TBRG50-5	1,155	18,927	5	19	225	102	33.75	857		
TBRG50-10	2,310	37,854	10	38	340	155	54.5	1,384		
TBRG50-15	3,465	56,781	15	57	490	223	78	1,981		

GENERAL DESIGN DATA

Maximum Working Pressure 5,000 PSI (345 Bar)

Maximum Proof Pressure 7,500PSI (517Bar)

Operating Temperature

(Buna/Nitrile) -20° to +200°F (-28° to 93°C)

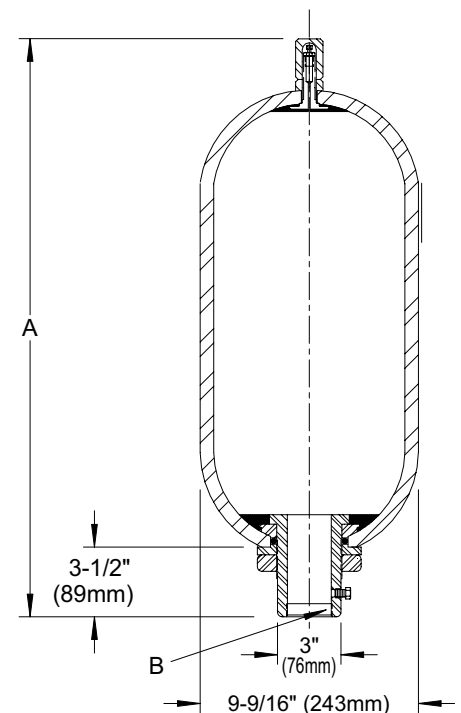

Gas Bottles

Cylindrical Carbon Steel

Gas Bottles may be fabricated similar to piston-type accumulators (less the internal piston), providing a wide variety of available capacities and physical dimensions.

This allows for an extensive range of capacities, much larger than available with forged shells. The versatility in application provides the system designer the ability to eliminate banks of multiple smaller capacity shells with a minimum number of higher volume fabricated bottles. This is especially valuable in applications where space (e.g., physical dimensions) and weight are critical.



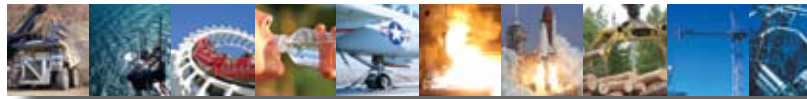

14AG30

Gas Bottles 3,000 PSI (207 Bar)

MODEL NUMBER	GAS CAPACITY				DRY WEIGHT		DIMENSION	
	In. ³	Cm. ³	GALLONS	LITERS	Lbs.	Kg.	A	
14AG30-120	3,476	56,955	15	57	759	344	41.25	1,048
14AG30-160	4,643	76,092	20	76	886	402	51.75	1,314
14AG30-200	5,783	94,774	25	95	1,010	458	62	1,575
14AG30-240	6,951	113,911	30	114	1,137	516	72.5	1,842
14AG30-320	9,259	151,729	40	152	1,388	629	93.25	2,369
14AG30-400	11,567	189,548	50	190	1,638	743	114	2,896
14AG30-480	13,875	227,366	60	227	1,889	857	134.75	3,423
14AG30-560	16,183	265,184	70	265	2,140	971	155.5	3,950
14AG30-640	18,490	303,003	80	303	2,391	1,085	176.25	4,477
14AG30-720	20,798	340,821	90	341	2,642	1,198	197	5,004
14AG30-800	23,106	378,640	100	379	2,893	1,312	217.75	5,531

GENERAL DESIGN DATA

Maximum Working Pressure 3,000 PSI (207 Bar)

Maximum Proof Pressure 4,500PSI (310Bar)

Operating Temperature
(Buna/Nitrile) -20° to +200°F (-28° to 93°C)

Larger volumes available upon request

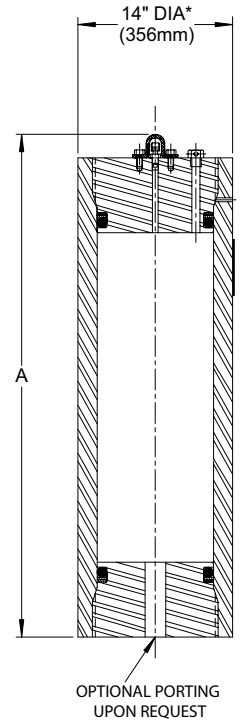

16AG50

Gas Bottles 5,000 PSI (345 Bar)

MODEL NUMBER	GAS CAPACITY				DRY WEIGHT		DIMENSION	
	In. ³	Cm. ³	GALLONS	LITERS	Lbs.	Kg.	A	
16AG50-120	3,476	56,955	15	57	1,406	638	43.75	1,111
16AG50-160	4,643	76,092	20	76	1,673	759	54.25	1,378
16AG50-200	5,783	94,774	25	95	1,934	877	64.5	1,638
16AG50-240	6,951	113,911	30	114	2,201	998	75	1,905
16AG50-320	9,259	151,729	40	152	2,728	1,238	95.75	2,432
16AG50-400	11,567	189,548	50	190	3,256	1,477	116.5	2,959
16AG50-480	13,875	227,366	60	227	3,783	1,716	137.25	3,486
16AG50-560	16,183	265,184	70	265	4,311	1,955	158	4,013
16AG50-640	18,490	303,003	80	303	4,839	2,195	178.75	4,540
16AG50-720	20,798	340,821	90	341	5,366	2,434	199.5	5,067
16AG50-800	23,106	378,640	100	379	5,894	2,673	220.25	5,594

GENERAL DESIGN DATA

Maximum Working Pressure 5,000 PSI (345 Bar)

Maximum Proof Pressure 7,500PSI (517Bar)

Operating Temperature
(Buna/Nitrile) -20° to +200°F (-28° to 93°C)

Larger volumes available upon request

