

Econolator II®

Open Top Bladder Accumulator Repairable

The “Econolator II®” is a Tobul product series which is a transition from piston-type accumulators to bladder-type accumulators, and incorporates characteristics of both designs...

- Utilizes a cylindrical steel cylinder with heads similar to piston-types. The fluid cap (bottom) is precision machine-welded into the steel cylinder to form a durable vessel.
- Utilizes an open top bladder available in a variety of sizes and elastomer materials (Buna-N/Butyl/EPR/Viton) similar to a diaphragm-type design. Whereas many diaphragm-type units are permanently sealed and non-repairable, the “Econolator II®” is repairable.
- Utilizes an upper cap and threaded ring assembly to retain and seal the open topped bladder, providing a simple “top-repairable” advantage; e.g., unit does not have to be removed from a vertically mounted application in order to replace bladder as long as Accumulator can be isolated from system pressure and physically accessible.
- Available in one quart and one gallon capacity at this time, with a one pint capacity unit to be released in the near future.

The EBR50 series (5,000 PSI) utilizes a threaded fluid end cap in addition to the upper gas cap and retaining ring assembly, similar to piston-type units.





EBR20 Accumulators 2,000 PSI (137 Bar)

MODEL NUMBER	GAS CAPACITY		FLUID CAPACITY		DRY WEIGHT		DIMENSION						
	In. ³	Cm. ³	Gallon	Liters	Lbs.	Kg.	A		B		C	D	
							In.	mm.	In.	mm.		In.	mm.
EBR20-30	29	475	0.12	.45	11	5	10	254	9.50	231	SAE-8	3.25	83
EBR20-60	58	950	0.25	1	25	11	10.125	257	8.875	225	SAE-12 or .75" NPT available as standard To specify .75" NPT, add "P" to end of model number	4.625	117
EBR20-231	231	3,785	1	4	55	25	18	450	16.75	425	SAE-16 or 1" NPT available as standard To specify 1" NPT, add "P" to end of model number	5.75	146

GENERAL DESIGN DATA

Maximum Working Pressure 2,000 PSI (138 Bar)

Maximum Proof Pressure 3,000 PSI (207 Bar)

Operating Temperature

(Buna/Nitrile) -20° to +200°F (-28° to 93°C)

Bladder for petroleum based oil.

ASME and other certification requirements may entail changes in materials, strengths, dimensional specifications and design parameters from those illustrated in this catalog.

Specifications subject to change without notice.

REPLACEMENT BLADDERS	
TYPE	PART NO.
1 Pint	SB-1247-30-B*
1 Quart	SB-1247-60-B*
1 Gallon	SB-1247-231-B*

* = Bladder Material Suffix

B = Buna-N E = Viton H = EPR

See Data Sheets for breakdown of parts.

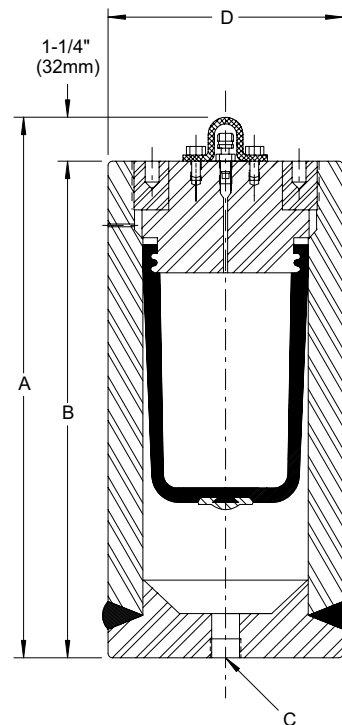

EBR30 Accumulators 3,000 PSI (207 Bar)

MODEL NUMBER	GAS CAPACITY		FLUID CAPACITY		DRY WEIGHT		DIMENSION						
	In. ³	Cm. ³	Gallon	Liters	Lbs.	Kg.	A		B		C	D	
							In.	mm.	In.	mm.		In.	mm.
EBR30-30	29	475	0.12	.45	11	5	10	254	9.50	231	SAE-8	3.25	83
EBR30-60	58	950	0.25	1	28	13	10.125	257	8.875	225	SAE-12 or .75" NPT available as standard To specify .75" NPT, add "P" to end of model number	4.75	121
EBR30-231	231	3,785	1	4	60	27	18	450	16.75	425	SAE-16 or 1" NPT available as standard To specify 1" NPT, add "P" to end of model number	6	152

GENERAL DESIGN DATA

Maximum Working Pressure 3,000 PSI (207 Bar)

Maximum Proof Pressure 4,500 PSI (310 Bar)

Operating Temperature

(Buna/Nitrile) -20° to +200°F (-28° to 93°C)

Bladder for petroleum based oil.

ASME and other certification requirements may entail changes in materials, strengths, dimensional specifications and design parameters from those illustrated in this catalog.

Specifications subject to change without notice.

REPLACEMENT BLADDERS	
TYPE	PART NO.
1 Pint	SB-1247-30-B*
1 Quart	SB-1247-60-B*
1 Gallon	SB-1247-231-B*

* = Bladder Material Suffix

B = Buna-N E = Viton H = EPR

See Data Sheets for breakdown of parts.

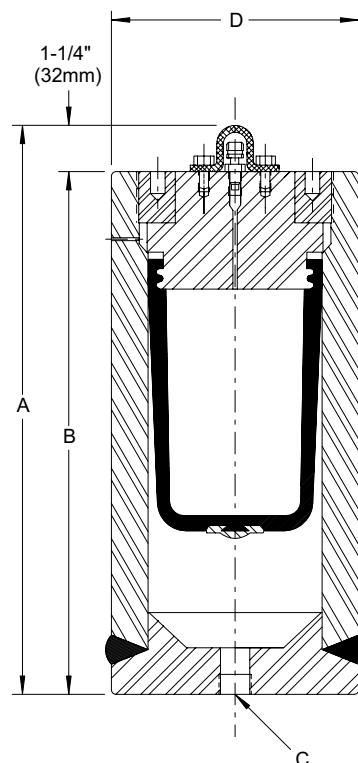

EBR50 Accumulators 5,000 PSI (345 Bar)

MODEL NUMBER	GAS CAPACITY		FLUID CAPACITY		DRY WEIGHT		DIMENSION						
							A		B		C	D	
	In. ³	Cm. ³	Gallon	Liters	Lbs.	Kg.	In.	mm.	In.	mm.		In.	mm.
EBR50-30	29	475	.12	.45	17	7.7	12.875	308	10.375	264	SAE-8	3.5	89
EBR50-60	58	950	0.25	1	52	24	12.75	324	11	279	SAE-12 or .75" NPT available as standard To specify .75" NPT, add "P" to end of model number	5.25	133
EBR50-231	231	3,785	1	4	104	47	20.25	514	18.5	470	SAE-16 or 1" NPT available as standard To specify 1" NPT, add "P" to end of model number	6.5	165

GENERAL DESIGN DATA

Maximum Working Pressure 5,000 PSI (345 Bar)

Maximum Proof Pressure 7,500 PSI (517 Bar)

Operating Temperature
(Buna/Nitrile) -20° to +200°F (-28° to 93°C)

Bladder for petroleum based oil.

ASME and other certification requirements may entail changes in materials, strengths, dimensional specifications and design parameters from those illustrated in this catalog.

Specifications subject to change without notice.

REPLACEMENT BLADDERS	
TYPE	PART NO.
1 Pint	SB-1247-30-B*
1 Quart	SB-1247-60-B*
1 Gallon	SB-1247-231-B*

* = Bladder Material Suffix
B = Buna-N E = Viton H = EPR
See Data Sheets for breakdown of parts.

